



HM Machinery Manufacture CO.,LTD

HM Machinery Manufacture

HSP-1N Rotary Latest Version Coffee Filling Sealing Machine



E-mail: hm005@hmmanufactory.com

www.coffeemachinesupplier.com

Add:NO.Tianfu Rd, Shanghai city, China .

PC: 201615



HM Machinery Manufacture CO.,LTD

HM Machinery Manufacture

Brief Instruction:

- * The whole machine stainless steel frame; **Organic glass cover (acrylic glass cover)**; one columns mould structure; Fixed castor and mobile pulley.
- * **Coffee servo screw filling, the filling volume can be adjusted on Touch screen, no cup no filling,**
- * **Automatic vacuum suck lids, No cup no Lids suck. Lids suck fault automatic stop.**
- * Lids Sealing, Omron temperature controller to adjust the temperature.
- * **Open the door, machine will stop automatic.**

Main Working Process:

- ☆ Automatic drop empty capsule to machine
- ☆ Sensor to detect whether there is lack of capsule or not, if lack of capsule, will stop machine automatic.
- ☆ Three times Nitrogen Filling
- ☆ Servo motor to fill coffee while vibrating, weight around 1-10g (can be adjust)
- ☆ Press coffee tightly and vacuum clean the edge of the cup after filling.
- ☆ Auto suck Foil Lids and put on capsule . (Lavazza will use roll film cutting and sealing)
- ☆ Auto detect whether the foil lids is ready by Sensor (If no lids, machine will stop and alarm)
- ☆ Auto Seal the lids.
- ☆ Finished product output.



HM Machinery Manufacture CO.,LTD

HM Machinery Manufacture

Technical Parameter:

| | | |
|-----|---------------------------------|---|
| NO. | Model | HSP-1N |
| 1 | Speed | Over 3000-3500Cups/hour |
| 2 | Working station | Rotary type 1 station |
| 3 | Filling range | 0-20grams |
| 4 | Filling accuracy | ±0.1g |
| 5 | Voltage | 280V 60HZ / 3KW |
| 6 | Air pressure gas consumption | ≥0.8Mpa / 0.1m ² |
| 7 | Working Temperature | 5-35°C |
| 8 | Relative humidity | ≤85% |
| 9 | Machine size | 1100mm (length) X1005mm (width) X1980mm (height) |
| 10. | weight | 600kg |



HM Machinery Manufacture CO.,LTD

HM Machinery Manufacture

Machine Detailed Show:





HM Machinery Manufacture CO.,LTD

HM Machinery Manufacture

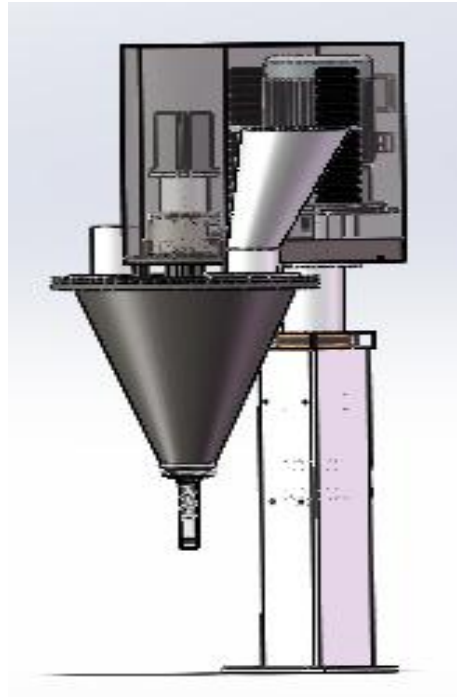

Servo motor for filling coffee

Heating:





HM Machinery Manufacture CO.,LTD

HM Machinery Manufacture

Nitrogen Filling :



Picture:

